

SECS4Hosts®

SECS4Hosts is a Microsoft® ActiveX® control and set of COM components that give your host applications the ability to communicate with any SECS-compliant equipment. Using best practices for Microsoft Windows® technology, SECS4Hosts enables fast integration with your host application and fast equipment interface development, yet we've maintained the flexibility you need to handle the unique SECS messages frequently encountered in equipment interfaces today.

Rapid application integration

As an ActiveX control, SECS4Hosts can be used in Visual Basic®, Visual C++®, or any other compatible ActiveX container. Such programming environments simplify interface design, speed development, and make integration with third-party tools and applications much easier.

For fast and complete integration with your host application, we expose the underlying SECS4Hosts COM components you can use in any COM-capable language, including the .NET languages.

With no need to write COM wrappers around libraries or to build functionality right into your communications driver, you can immediately start using the SECS4Hosts object model to develop robust host applications.

And, because using forms in background applications is not recommended in Visual Basic and is very complex in C++, the SECS4Hosts COM components provide a significant advantage. The best part is, your host application needs to know nothing about the SECS interface on the equipment. It just needs to use the methods, events, and data required to do its job.

Rapid equipment integration

The enabling technology for rapid equipment integration is the Transaction Editor, an easy-to-use configuration tool for setting up the messages and data items your equipment supports.

Instead of coding these formats in your application, you simply reference the XML configuration file created for the equipment by the Transaction Editor.

The Transaction Editor gives you the option of creating your configuration file

- ▶ from scratch
- ▶ based on a standard library of all SECS-II messages and data types
- ▶ based on a library of SECS-II messages and data types specified in the GEM standard

All you need to do is modify the standard formats to fit your particular machine characterization. If you are setting up GEM-compliant equipment, your configuration file will be ready in a matter of minutes.

To get a quick start on your project, you can start developing specific equipment configuration files prior to completing integration with your host application.

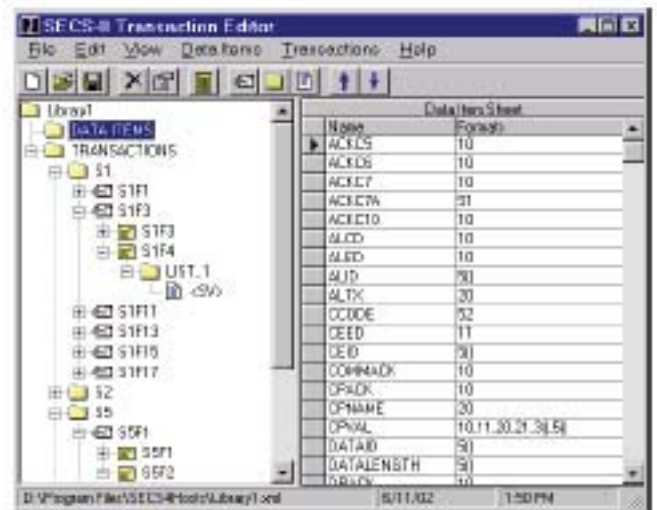
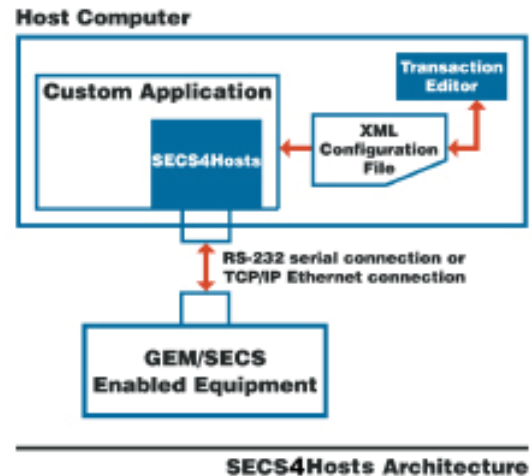

Flexible and easy to use

If your equipment has additional functionality that uses non-standard messages, you can use the Transaction Editor to create new SECS-II messages and data items that fit your equipment's unique characterization.

You can also use the editor to update your equipment's configuration at any time. This lets you implement SECS communications on an as-needed basis and respond to changing data collection needs with speed and simplicity.

This configuration information is stored in an XML file that can be modified easily, shared with other applications, and used to document your equipment characterization. Once you create the XML configuration file for a piece of equipment, you can reference it from any application that uses the SECS4Hosts control. You can also develop a single application for all equipment of the same type and simply use the appropriate XML file for each equipment interface.

SECS4Hosts Features

SECS4Hosts has many features that make it easy to integrate with your host applications.

FEATURES

- ▶ Object-based model simplifies SECS messaging
- ▶ Event-driven programming model eliminates the need to poll equipment
- ▶ Full SECS-I, SECS-II, and HSMS support
- ▶ Ability to view the raw SECS-II messages
- ▶ Equipment characterization stored in an XML file; information is configurable at any time
- ▶ Ability to configure communications protocols instead of coding them
- ▶ Ability to modify existing messages at runtime and compile time

System requirements

- ▶ Windows NT® 4, Windows 2000, or Windows XP

SEMI Standards

- ▶ E04 SECS-I
- ▶ E05 SECS-II
- ▶ E30 GEM
- ▶ E37 HSMS

About PEER Group

PEER Group provides innovative factory automation software solutions and consulting services to the semiconductor, photovoltaic, and electronics industries. The world's best manufacturing companies turn to PEER Group to solve their most challenging equipment automation, data management, and process control problems. With more than 100,000 licenses shipped, we are the world's leading supplier of equipment connectivity and testing products to automated factories around the globe. Our innovative and reliable products and services help lower the cost of automation for high-volume manufacturers and their equipment suppliers.

www.peergroup.com

PEER Group® is a registered trademark of The PEER Group Inc. in the United States and Canada.
SECS4Hosts® is a registered trademark of The PEER Group Inc. in the United States